



CS6MX

Operating Instructions

C:SCOPE

CS6MX

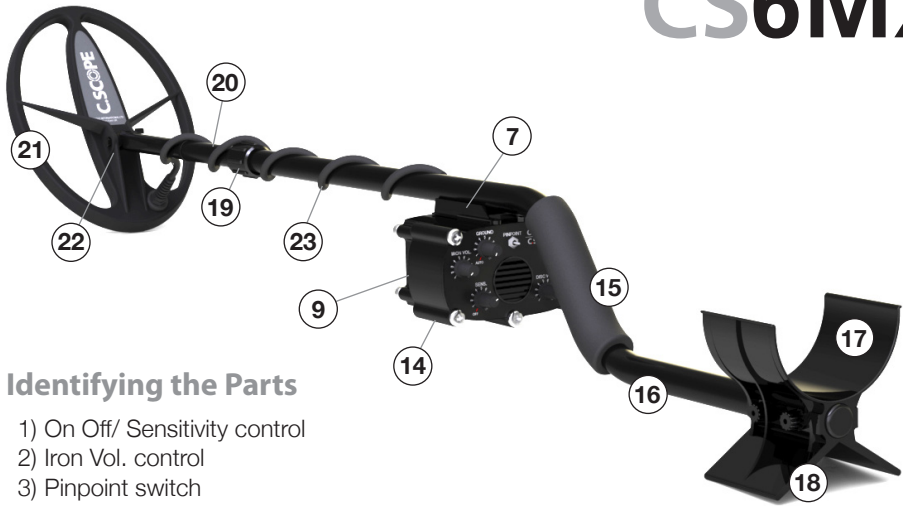

Identifying the Parts

- 1) On Off/ Sensitivity control
- 2) Iron Vol. control
- 3) Pinpoint switch
- 4) Disc Vol. control
- 5) Disc control
- 6) Ground control
- 7) Control box mounting clip
- 8) Loudspeaker
- 9) Battery compartment
- 10) 8 x AA battery holder
- 11) Battery contacts
- 12) Search-head socket
- 13) Headphone socket
- 14) Control box
- 15) Hand grip
- 16) Upper stem
- 17) Arm support
- 18) Detector rest
- 19) Stem lock
- 20) Lower stem
- 21) Interchangeable Search-head
- 22) Search-head fixing screw and wing-nut
- 23) Search-head lead

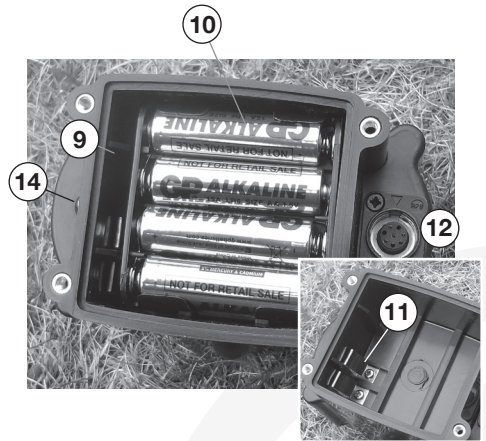



CS6MX Overview

The CS6MX is a high performance specialist metal detector operating on the 'MOTION' principle. This means that the search-head must be kept moving at a steady sweep speed to achieve optimum performance. The 6MX features multiple discrimination allowing the user to detect the smallest and thinnest coins on the most heavily contaminated or mineralised sites.

The CS6MX provides the option of interchangeable search-heads to optimise performance on a variety of site conditions. There is an iron volume control alongside a discrimination control with discrimination volume to aid identification of targets; a pinpoint switch to aid exact target location; and a manual / auto ground option to handle all ground conditions

The CS6MX is designed to offer extremely high performance and, with practice, will give you excellent results. We wish you good hunting and a great hobby with the excellent CS6MX!

Rapid start

Follow these simple steps to start using the CS6MX within minutes:

- 1) Insert the lower stem into the upper stem (first press in the spring clip).
- 2) Twist the locking device so that the stem is locked at the required length.
- 3) Coil the search-head lead around the stem.
- 4) Plug the search-head lead into the socket on the control box.
- 5) Remove the battery compartment cover by loosening the four retaining screws.
- 6) Fit 8 x AA batteries to the battery holder being careful to observe polarity and good contact and replace cover.
- 7) Rotate the Iron Volume control to number 8 on the scale.
- 8) Rotate the Disc control to number 4 on the scale.
- 9) Rotate the Disc Volume control to number 8 on the scale.
- 10) Set the Ground Control to 'AUTO'.
- 11) Switch on and rotate the Sensitivity control to number 8 on the scale.
- 12) START DETECTING... Good metal targets give a sharp, high pitched audio signal from the loudspeaker... Targets that have been discriminated will be identified by a low tone... Signals from small pieces of iron are ignored... Switch to pinpoint to identify the exact position of the target.



The CS6MX Features and what they do

1) On Off/Sensitivity control.

Rotary control switches the detector on/off and adjusts the sensitivity. Ground containing mineralisation and some beach situations may cause instability or false signals requiring a reduction of the sensitivity level.

2) Ground Level control.

Start off with this set to AUTO. Extra sensitivity can be achieved on consistent ground by adjusting this control manually in conjunction with the sensitivity control (see section 'Detecting with the CS6MX').

3) Pinpoint

The 'motion' aspect of the CS6MX is switched off whilst the pin-point mode is selected (switch in up position). In pin-point mode the search-head can be held still to determine the precise target position. Pinpoint mode operates in 'All Metal', ie. whatever level of discrimination you have chosen will be switched off while the pin-point button is depressed. This is a useful facility which allows you to trace around the edges of a signal to identify large pieces of iron. (*Note: very large pieces of iron, such as discarded agricultural machinery and iron stakes tend to give positive signals even when the detector is set to high discrimination settings*). Once the pinpoint switch is released the detector returns to motion mode.

4) Iron Volume control.

Iron targets are identified by a low pitched tone. The volume level of this low pitched tone can be adjusted as required. To ignore iron this control should be set to zero.

5) Discrimination Level control.

This is used to set the discrimination point. When fully anti-clockwise, the detector will respond to any target from silver paper to gold with a high pitch tone. As the control is rotated clockwise, the lower conduction metals are identified by a mid pitch tone.

6) Disc Volume control.

Used in conjunction with (5), the Volume level of the mid pitch tone can be adjusted as required.

7) Control box mounting clip.

For ultimate lightweight metal detecting the CS6MX control box can be removed and fitted to a belt around the body. This leaves only the search-head on the stem which reduces fatigue on the arm.

8) Loudspeaker (and battery condition indicator).

The presence of metal is indicated by a short tone from the loudspeaker as the search-head is passed over a target.

Assembling the CS6MX

The stem lock should be slackened to allow the lower stem to enter the upper stem section. The spring clip should be pressed in to allow the lower stem to slide into the upper stem. This spring clip will pop into any of the holes in the upper stem and firmly fix the two stems together. Tighten the stem lock to stop any movement in the stems. The search-head lead may then be wound around the stem as shown in the photograph. A search-head lead which is not well secured to the stem could move about causing false signals. Cable ties or tape may be used to hold the lead in position. Align the arrows on the plug and on the socket to connect the search-head lead to the control box. Adjust the position of the search-head so that it is parallel to the ground when the user is in a normal standing position. Tighten the wing-nut on the search-head retaining screw. Do not over-tighten. Friction of the head lugs against the neoprene washers keeps the search-head in position. Excessive pressure on these parts should not be necessary. *(If some form of lubricant should ever find its way onto these washers it will be necessary to disassemble the parts, wash and dry them before careful reassembly).*



Changing Search-heads

Each search-head is supplied complete with a lower stem to make changing easy. Unplug the connector by pulling the plug outer case. This releases the catch to allow the plug and socket to separate. Remove the lower stem assembly and refit the alternative search-head. Always take care not to get water or dirt in the plug or socket. It is for this reason that we recommend changing heads in clean conditions. Coil the search-head lead tightly around the stem and fix with cable ties or tape for best performance. Align the arrows on the plug and on the socket when connecting the search-head lead.

Belt mounting

Squeeze the control box retaining clips together using your thumbs as shown in the photograph. The control box will now slide towards you free of the control box mounting clip. The control box can be fitted to your belt using the clip provided. In belt mounted use, be sure to wind the search-head cable up the stem at least to the stem lock and secure it with tape or cable tie. This is because the lead will be detected like a target if it is left free to move.



Above: Slide the belt mounting clip into the fixing slots on the underside of the control box and push all the way until the retaining lugs click into position.

Batteries

Undo the 4 battery compartment retaining screws and take out the battery holder. Fit eight good quality AA type batteries into the compartments of the battery holder. Observe polarity of the batteries (the spring contact goes against the flat, negative end of the battery). Roll the batteries in the holder to ensure good contact and replace into the battery compartment with the contacts on the holder lining up with the contacts in the compartment. Replace the battery compartment cover being careful to avoid cross threading the screws. Battery condition is monitored continuously on the CS6MX. Low batteries are indicated by a warble alarm repeated every few seconds.



Detecting with the CS6MX

On the majority of inland sites the ground control should be set to AUTO and the recommended sensitivity setting between 7-9 on the scale will give the best results. Some types of ground may give rise to false signals and the sensitivity level should be reduced to a point where operation of the detector becomes stable.

Sweep the detector head from side to side with a steady relaxed motion. Keep the search-head parallel and as close as possible to the ground right across the arc of the sweep.

Search your chosen site carefully by moving forward only the width of the search-head at each sweep. Move up and down the search area in lines so that there is plenty of overlap in the ground you have covered. Search with the sensitivity set as high as possible according to the ground conditions.

Setting the GROUND control.

With GROUND set to AUTO and with DISC VOL and IRON VOL set to maximum, find an area which is free from metal.

- a) Switch the GROUND control out of the AUTO setting to position 1.
- b) Gradually increase the GROUND control until the low (iron) tone produced by the ground as the search head is raised and lowered, stops.
- c) Reset the DISC VOL and IRON VOL to your preferred setting.

Searching.

When the detector gives a signal, move the search-head to the approximate area where the signal was heard, hold the switch in pinpoint and move the search-head carefully around. The strongest signal will occur directly below the centre of the search-head. Dig a neat hole by cutting around the signal position with a sharp edged trowel and remove a divot of earth which might now contain the metal object. Run the detector over the area again in pinpoint mode to see if the metal object is still in the hole or in the piece of earth which you have just removed.

Dig some more and sift through the earth until you find what you are looking for. Fill in the hole before moving on.

The use of headphones will increase battery life and make it easier to discern faint signals.

Follow the 'Countryside Code'. Do not trespass. Do not touch anything you suspect might be live ammunition - inform the police.

Do not take your detector on any scheduled historic site. If you find anything which looks like it could have historical significance, report it to your local museum.

Acquaint yourself with any laws relating to the use of metal detectors particularly if you want to go detecting in countries other than the UK.

Sensitivity, ground effect & discrimination

You will be able to get more performance out of your detector if you understand the relationship between three aspects of detector operation - sensitivity, ground effect and discrimination.

If you increase the power of a metal detector too much the ground itself is detected and false signals make the detector difficult to use. The 'motion' electronic system of the CS6MX will ignore many ground effect signals but some types of ground, notably waterlogged or containing salts or mineralisation require the detector to operate on reduced sensitivity.

However, the discriminate control must be used with care because some objects, which could be valuable, have similar electrical characteristics to rubbish items as far as the detector can tell. Higher levels of discrimination also have the effect of reducing the depth of detection. For these reasons it is best to keep the discrimination setting as low as possible.

Depending on how the controls are set the CS6MX can be set to ignore signals from certain types of metal targets. Iron targets are identified by a low pitch tone, however you can adjust the volume level of this tone so it can be clearly heard or totally inaudible. The three tone discrimination is further enhanced by the Discrimination control in conjunction with the Discrimination Volume control.

The discrimination control is used to determine the detector's response to 'mid range' targets such as foil, nickel and 9ct gold. with the control set to minimum, (and the disc volume set to maximum) every target apart from iron will give a high pitch tone. As the control is turned progressively clockwise, the response from these metals will then become a mid pitch tone. It is then possible to reduce the disc volume on these targets so that only targets above discrimination point are identified. This can be used to ignore the effects of coke contamination.

Discrimination Chart.

SETTING		RESPONSE			
DISC LEVEL	DISC VOLUME	COKE TONE	FOIL TONE	SMALL SILVER HAMMERED (CUT HALF) TONE	LARGE SILVER HAMMERED TONE
MIN	MIN	HIGH	HIGH	HIGH	HIGH
	MAX	HIGH	HIGH	HIGH	HIGH
MID	MIN	NONE	NONE	HIGH	HIGH
	MAX	MID	MID	HIGH	HIGH
MAX	MIN	NONE	NONE	NONE	HIGH
	MAX	MID	MID	MID	HIGH

Actual performance will depend on site and soil conditions as well as target size and orientation.

Many users will enjoy the full three tone audio discrimination by setting the the Iron Volume control to 8, the Disc control to 6 and the Disc Volume to 8.

Detector care

The CS6MX is a robust design, however the control box should be treated with similar care as any electronic product. Dry off any water splashes immediately. The search-head may be immersed in water although the connector at the other end of the lead should always be kept dry. Stem and search-head parts should be cleaned and dried at the end of a day's detecting. Do not use solvents. If the detector has been used on a beach it will be necessary to wash sand and salt residue off the stem adjustment mechanism and the search-head retaining parts using tap water. The use of a search-head cover protects the head from abrasion damage caused by friction with the ground. Remove batteries if the detector is going to be stored for any length of time.

Do not open the controlbox front panel. There are no user serviceable parts inside and you may invalidate your warranty.

Warranty & Service

Your CS6MX is guaranteed free of manufacturing defects as confirmed in our written warranty. Contact us if you have any concerns about the operation of your detector.

The C.SCOPE Customer Service Team really know about metal detectors and are always ready with good advice and rapid after-sales-service.

Caution

It is the user's responsibility to use this product and dig only where it is safe to do so.

C.SCOPE is an ISO 9001 Accredited Quality Manufacturer.
This equipment conforms to the EMC directive 89/336/EEC.
System performance may be impaired by unusually strong electromagnetic fields.

Waste electrical products should not be disposed of with household waste.
Please recycle where facilities exist. Check with your local authority or retailer for recycling advice. (In the UK visit www.recycle-more.co.uk)



C.SCOPE

C.SCOPE INTERNATIONAL LTD
KINGSNORTH TECHNOLOGY PARK
WOTTON ROAD ASHFORD
KENT TN23 6LN UK

Telephone: +44 (0)1233 629181

Fax: +44 (0)1233 645897

email: info@cscope.co.uk

web: www.csmetaldetectors.com